



Via A. Marino 15/17 – 20090 Fizzonasco di Pieve Emanuele (Milano) – Italia
Tel: +39 02 90420257 - +39 02 90723468 – Fax: +39 02 90723469 – Skype: mismatic
E-mail: info@mismatic.com – Website: www.mismatic.com

multi-field

automatic loader



Description

The automatic loader has been designed and built to handle rigid materials such as **metal, glass, plastic sheets** and **wooden panels**.

Working

1. The sheet (or the panel) is placed vertically into the rack.
2. The suction cap system takes the sheet and spins it of about 90° (that is parallel to the ground).
3. The loader handles the sheet towards the roller-table of the production line and then it lays down the sheet over the roller-table.

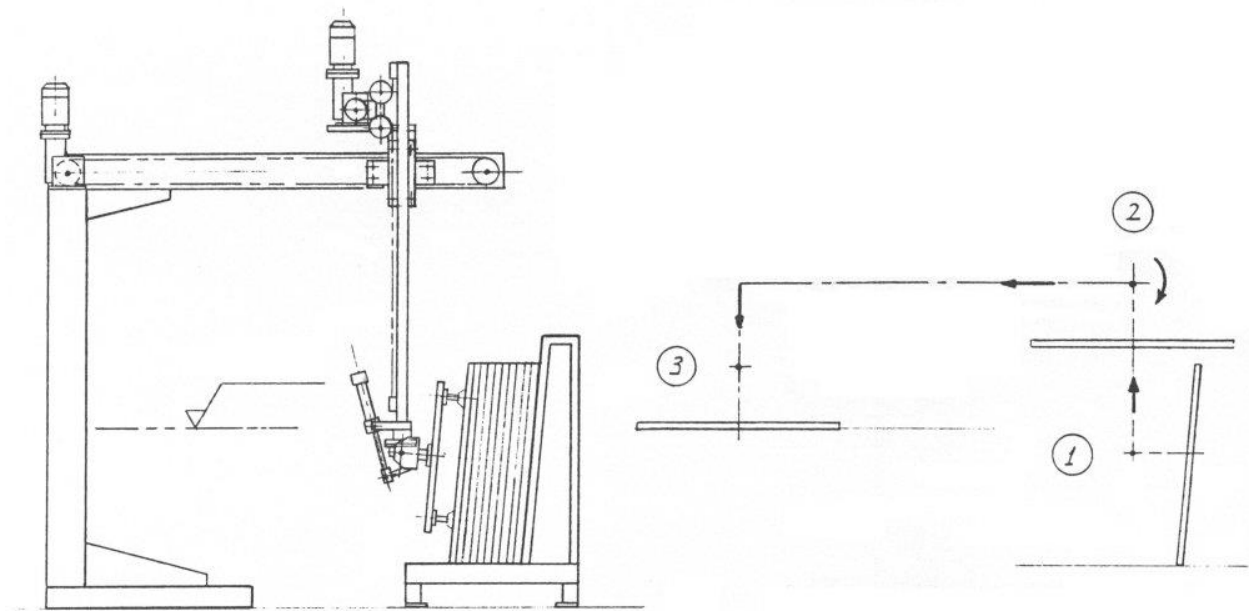

Technical data	
<i>Suitable materials:</i>	metal, glass, plastic sheets and wooden panels
<i>Max loading speed:</i>	100 sheets or panels per hour
<i>Max material size¹:</i>	1500 mm x 3000 mm
<i>Max weight²:</i>	100 kg per sheet or panel
<i>Electrical supply³:</i>	400 V three-phase + neutral, 50 Hz
<i>Installed power:</i>	1 kW
<i>Overall dimensions:</i>	(L) 1600 mm x (W) 3000 mm x (H) 3800 mm

[1] Any other size available on request.

[2] Any other weight available on request.

[3] Any other three-phase electrical supply available on request.

To improve the quality of the product, the Mismatic Company can effect modifications in the manufacturing without any obligation to notify these to the Customer.

Standard features

- ❖ **Equipped with 8 suction caps**
- ❖ **You can adjust the gap between the suction caps**
- ❖ **Control panel on board**